

*Introducing Andover Fabric's new collection – Inspired by the
Sophia M. Pearce Quilt c. 1840, in the archives of the
Winterthur Museum and Country Estate*

Little Sophia Quilt



Quilt designed and made
by Gail Kessler
Quilted by Carol Heisler
Finished size: 74" x 74"



makower uk[®]

1384 Broadway · New York, NY 10018 · (800) 223-5678

www.andoverfabrics.com

- Free Pattern Download Available -

Little Sophia Quilt

Quilt designed and made by Gail Kessler and quilted by Carol Heisler

Inspired by the Sophia M. Pearce Quilt c. 1840, in the archives of the Winterthur Museum and Country Estate

Fabric Requirements and Cutting Directions

For best use of fabric, cut strips and patches in order given. Refer to Cutting Diagrams A and B when cutting Green Triangle strips. Prepare plastic template by drawing a 10-1/4" square on see-through template plastic. Cut square in half diagonally for Template A triangle (used to cut bouquets from scalloped border print). Template A triangle includes 1/4" seam allowance.

3406-L Beige Texture – 1 fat eighth*

Cut (4) 2-3/8" squares

3404-G Green Floral with Beige Floral Scallops – 6-3/8 yds.

Cut from beige/scallop portion of fabric:

Cut (4) Template A triangles**

Cut (4) 9-3/4" x 84" strips, centered on green scallop (see quilt photo)

Cut from green portion of fabric:

Cut (4) 2-1/4" x 83" strips, cut on lengthwise grain for binding

Cut (4) 2-3/8" squares

Cut (4) 4-1/2" squares, cut in half diagonally to make (8) half-square triangles

3403-G Green Triangle/Brown Medallion

Border Stripe – 3 yds.

From green triangle stripes:

Cut (8) 2" x 14" strips, beginning strip 1/4" to left or right side of green triangle as shown (See Cutting Diagrams A and B)

Cut (4) 2" x 23" strips, centered on point of beige triangle

Cut (4) 2" x 39-1/2" strips, centered on point of green triangle

From brown medallion stripes:

Cut (2) 5-1/2" x 29-1/2" strips, centered on stripe

Cut (2) 5-1/2" x 39-1/2" strips, centered on stripe

3401-L Large Floral Bouquet Print – 3/4 yd.

Cut (1) 21" square, centered on bouquet of choice

3402-L Floral Print – 2 yds.

Cut (2) 32" squares, cut in half diagonally to make (4) half-square triangles

Backing Fabric – 4-3/4 yds.

Other Materials: Template plastic (see through)

Batting – Queen Size

*A fat eighth is a 9" x 20-22" cut of fabric.

** Center template on bouquet within scallop, avoiding green.

Mark around template and cut out. Cut 4 total.

Quilt finishes approx. 74" x 74"

Assembling the Quilt Sections

Referring to Diagram I, draw diagonal line on wrong side of beige 2-3/8" square. Place marked square, right sides together, on green 2-3/8" square. Stitch 1/4" to each side of marked line. Cut apart on marked line. Press open to make two pieced squares. Make eight.

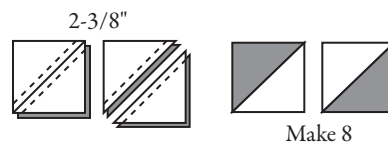
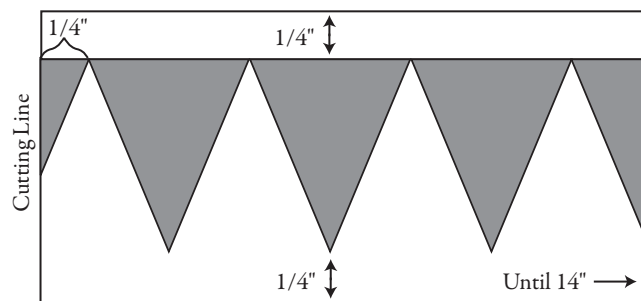

Diagram I

Watching orientation, stitch green triangle 2" x 14" strip (Cutting Diagram A) to side of 2-3/8" pieced square (Diagram II-A). Stitch green triangle 2" x 14" strip (Cutting Diagram B) to side of Template A triangle. Referring to Diagrams II-B through II-F, make four pieced triangles.

Cutting Diagram A

Cut 4 with 1/4" to left



Cutting Diagram B

Cut 4 with 1/4" to right

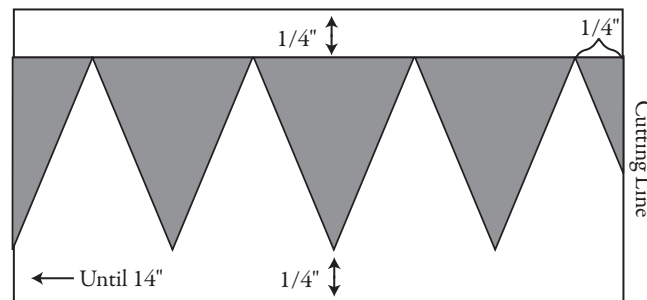

Little Sophia Quilt

Section A – Pieced Triangle – Make 4

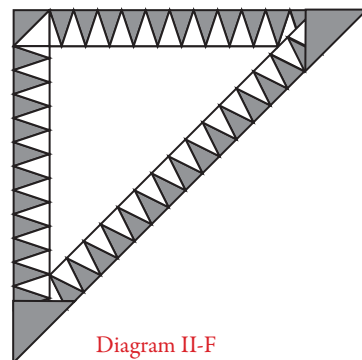
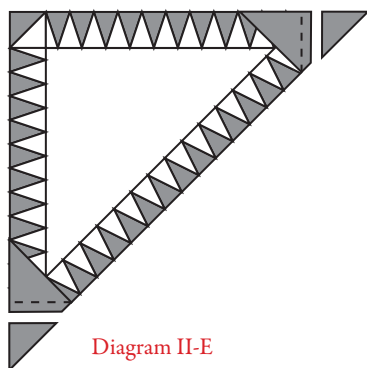
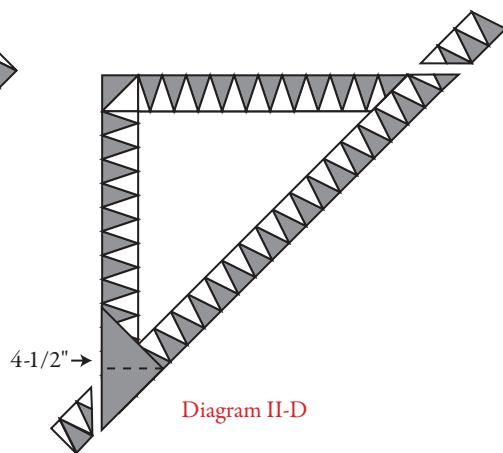
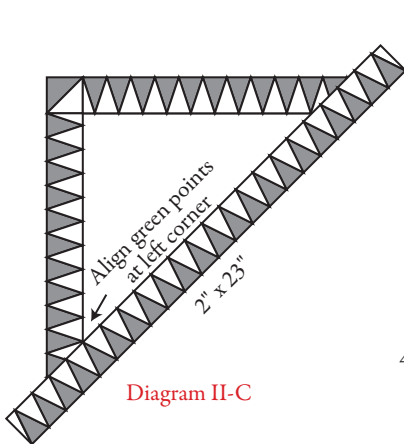
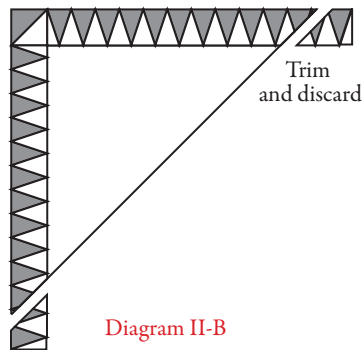
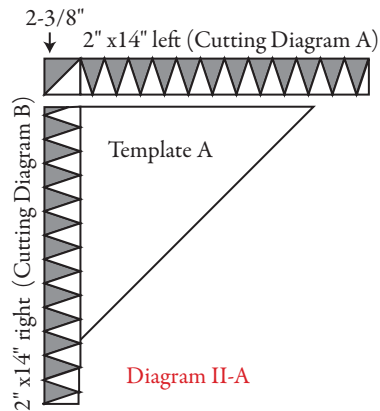

Assembling the Quilt Top

Note: Refer to Quilt Diagram and photo for following steps.

Stitch two pieced triangles to sides of floral bouquet 21" square. Stitch remaining pieced triangles to the top and bottom of square. Stitch brown medallion 29-1/2" strips to sides. Stitch brown 39-1/2" strips to top and bottom.

Sew two green triangle 39-1/2" strips to sides. Watching orientation, stitch 2-3/8" pieced squares to ends of remaining green triangle strips; sew to top and bottom.

Note: Half-square triangles are cut slightly oversized to allow for trimming. Stitch floral print 32" half square triangles to sides of quilt. Stitch remaining half square triangles to top and bottom of quilt. Trim even.

Centering green scallop, stitch four border strips to quilt, starting and stopping 1/4" from raw edges; back-stitch to secure. Press seam allowances toward quilt top. Stitch miter and trim excess fabric.

Quilting and Finishing

Layer quilt top with batting and batting (both cut 8" larger than quilt top). Baste and quilt as desired. Bind with green floral strips.

Quilt Diagram

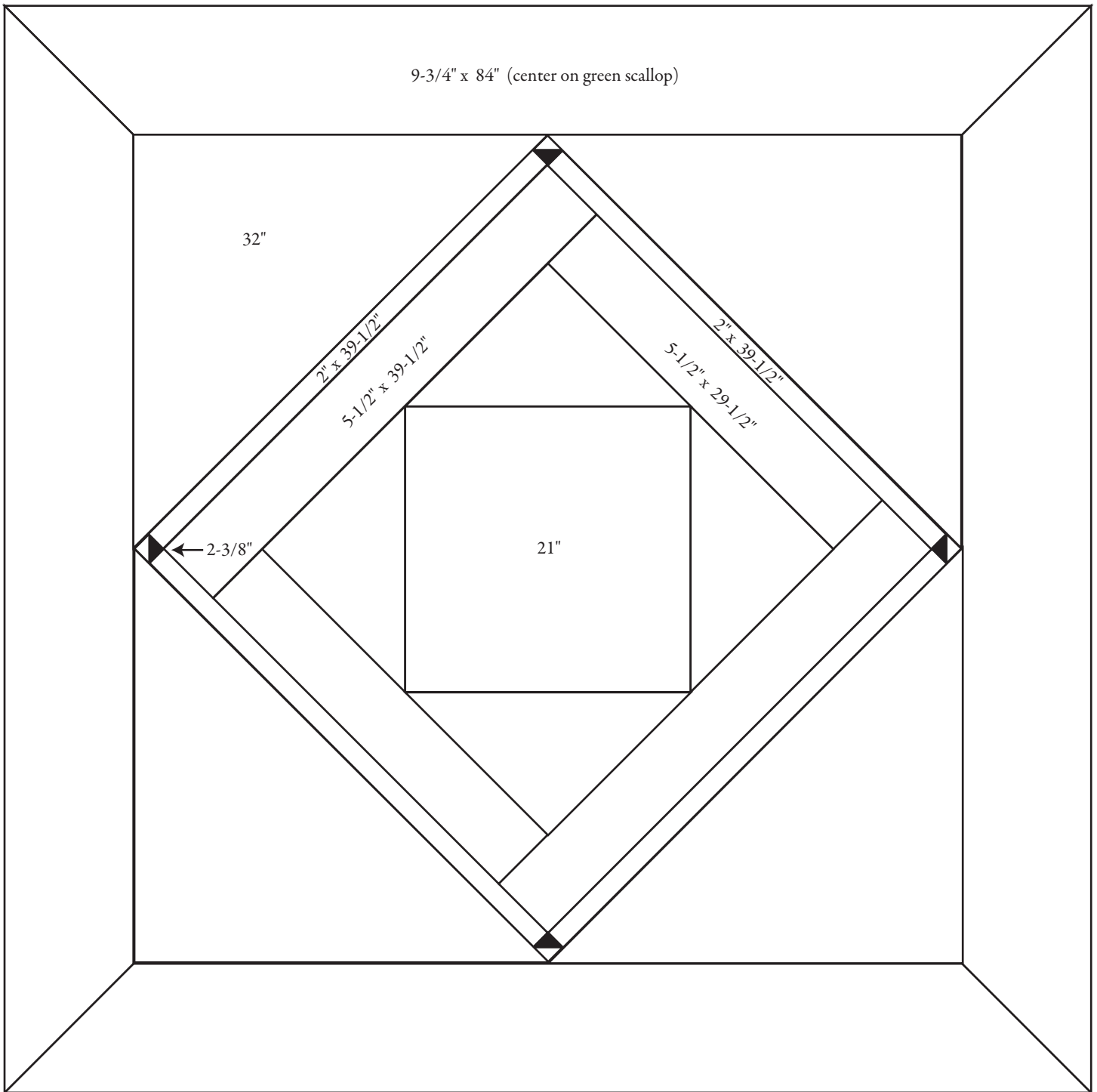

1384 Broadway
New York, NY 10018
(800) 223-5678
www.andoverfabrics.com

The Sophia Pearce Collection

Winterthur Museum under license to Andover Fabrics



3401-L



3406-L



3402-L



3403-B



3405-B



3405-G



3403-G

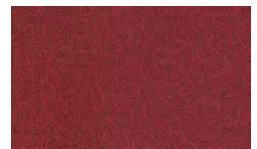

3405-R



3405-P



3404-B



3404-G



3405-Y

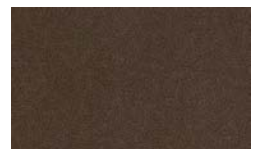

3405-N